

Speedplay Cleat Wedge

Installation Instructions

Form No. 0410104

Speedplay (4-hole style)

1° tilt per Wedge

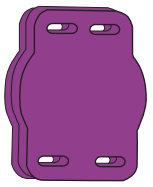

4 x 12 mm



4 x 14 mm

Compatible with:
• Speedplay

8 x Wedges
per box

Tools Required:

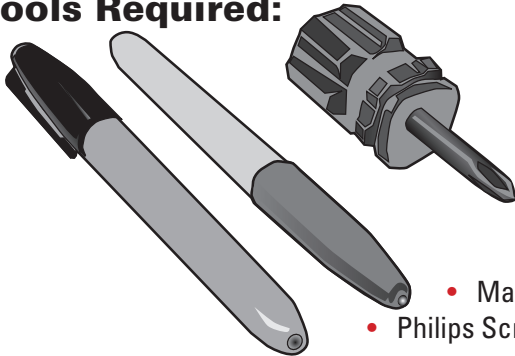

- Marking Pen
- Philips Screwdriver

Why a Wedge?

Recent studies show 96% of all cyclists are misaligned in their connection to the bicycle, decreasing comfort & efficiency.

BECAUSE... 87% of people with feet have a forefoot that tilts up & to the inside (Forefoot Varus) and 9% of people with feet have a forefoot that tilts up and to the outside (Forefoot Valgus). ALL conventional pedal systems require a cyclist to connect to the pedal flat-footed. Without correction, this predisposes cyclists to mechanical defects in their pedaling stroke.

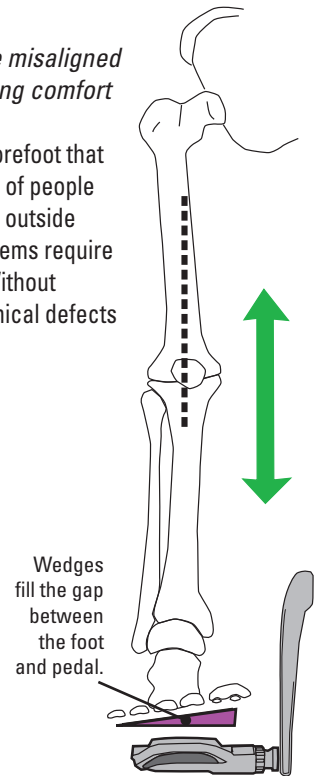
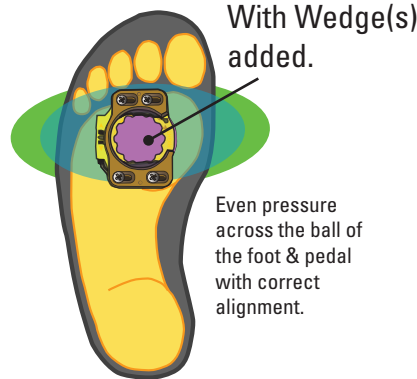

STEP

1.

How to measure Forefoot Tilt:

Please visit your nearest BikeFit Pro, who will be able to measure both of your feet with the Forefoot Measuring Device (FFMD). This is a measurable way to determine the starting point for your Cleat and the number of Cleat Wedges you may need for each foot. To learn more, see the process pictured below. Or view more online at www.BikeFit.com



- a.** Kneel on a chair, facing the back, with relaxed feet extending over the edge.

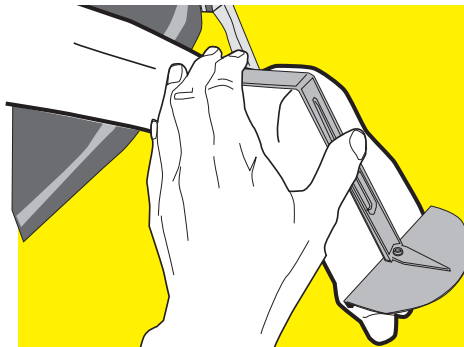

- b.** Your BikeFit Pro will place the Forefoot Measuring Device (FFMD) on the bottom of each foot pushing the handle against the heel so the vertical portion is aligned dividing the heel in two equal halves. The FFMD can be purchased separately at www.BikeFit.com.

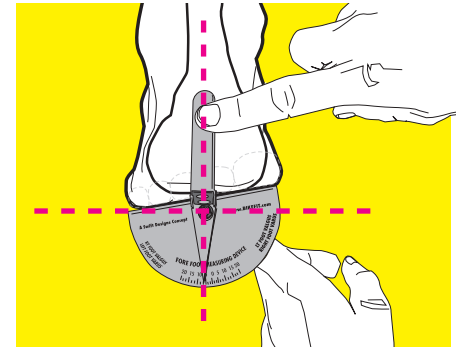

- c.** With FFMD in place, position the top flat surface of the Device (½-circle protractor portion) on the ball of the foot. Make a note of the angle indicated by the protractor. Repeat this procedure 3 times for each foot & average the numbers separately. Use this as your starting point. See reference charts found online at BikeFit.com

STEP 2.

Mark your Cleats

Use a marking pen to draw reference lines on the cleats and shoe sole to aid installation/reinstallation of cleats.

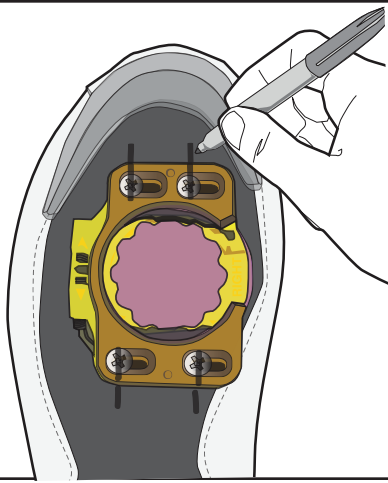

STEP 3.

Install Cleat Wedges

Remove old cleats from shoe. Make sure to remove any debris or dirt from the mounting holes in the shoe sole.

Visit www.speedplay.com to find what works best for your type of shoes.

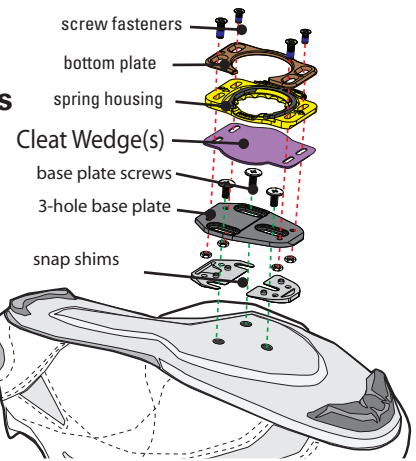

STEP 4.

Ensure cleat to shoe compatibility

Do not overtighten 3 base plate screws to cause base plate deflection to curved shoe soles. This is more often with smaller sized shoes. Speedplay includes Snap Shims with cleats that will help (See Step 3).

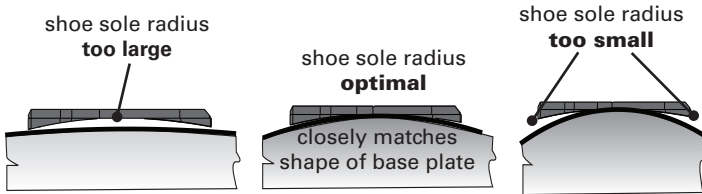

STEP 5.

Adjusting the Cleat position.

a. Your Cleat has an adjustment range front to back (via base plate), right to left and rotation on the shoe. After practicing engagement and release from pedal, readjustment may be needed for best cleat position.

b. After determining best cleat position, firmly and evenly tighten screw fasteners.

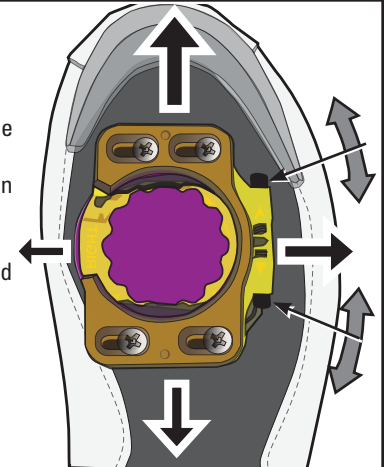

STEP 6.

Adding Cleat Wedges

Add or subtract any Cleat Wedges, as necessary, to maximize comfort & increase your knee-over-pedal alignment.

Treat each foot independently. One foot may feel better, with more or less Cleat Wedges, than the other.

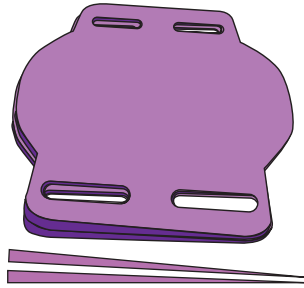

STEP 7.

Go for a short, easy test ride.

Finally secure, but do not overtighten your cleat bolts (which can cause them to fail). Use a torque wrench following the cleat manufacturer's guidelines for proper torque.

If you are unsure about this process, get assistance from your local BikeFit Pro. Also visit Speedplay.com fit tech online videos.

Remember always **let comfort be your guide.**

General Safety Information

⚠️ WARNING – To avoid serious injuries:

- BikeFit CleatWedges and cleat protrude out from the surface of your shoes and may therefore mark or scratch floor surfaces.
- Cycling shoes may not provide adequate traction for walking on wet and/or smooth surfaces. Use extreme caution when walking on any surfaces in order to avoid a serious injury.
- Understand how the locking mechanism of your pedals functions with your Cleats and understand how they work before you ride.
- Before riding, place one foot on the ground and practice engaging and disengaging from the pedal a number of times until you get used to it. Repeat this for both feet.
- Practice riding on smooth ground, void of traffic, first.
- Always let comfort be your guide when adding or subtracting the optional Cleat Wedges. Treat each foot independently.
- Before riding, adjust the retention force of the pedal to your liking (Refer to the adjustment instructions for your current pedals on your bike.).
- Make sure that mud, dirt, and foreign objects don't build up in the pedal-cleat interface area.
- If you do not maintain both your shoes and cleats in good condition, release and engagement to the pedals could become unpredictable or difficult, which could result in severe injury.
- If you have any questions regarding methods of installation, adjustment, maintenance or operation, please contact a BikeFit Pro for assistance.
- Read these Instructions carefully & keep them in a safe place for later reference.

BE SURE TO READ AND FOLLOW THE ABOVE WARNINGS CAREFULLY. IF THE WARNINGS ARE NOT FOLLOWED, YOUR SHOES MAY NOT COME OUT OF THE PEDALS WHEN YOU INTEND OR THEY MAY COME OUT UNEXPECTEDLY OR ACCIDENTALLY, AND SEVERE INJURY MAY RESULT.